

HAFCO

OPERATION MANUAL

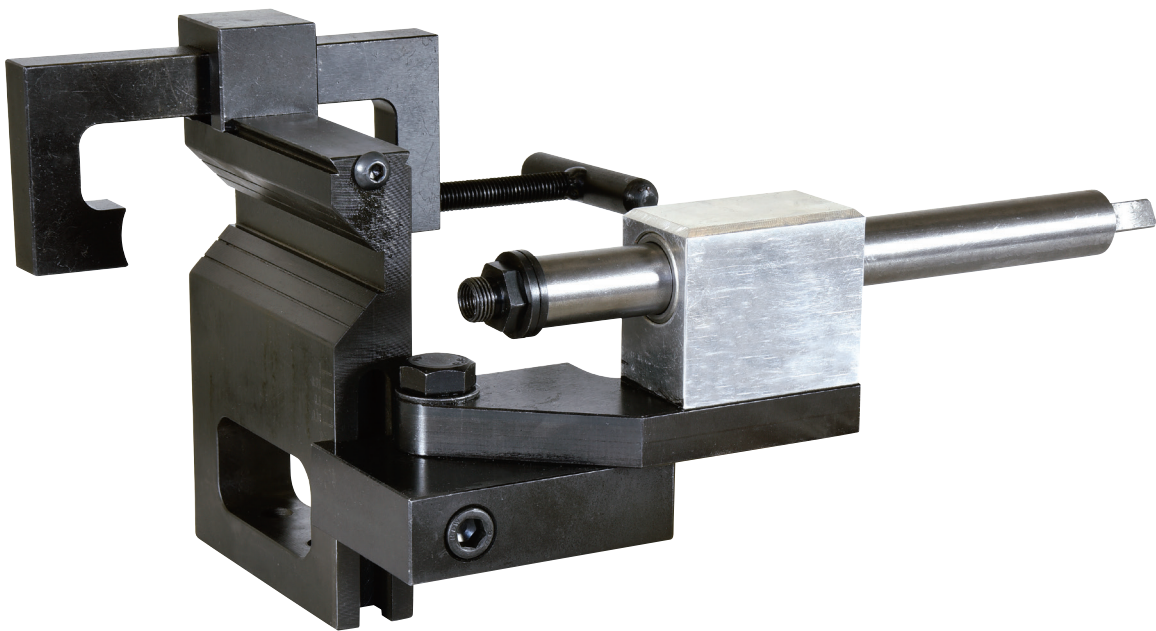

OFFSET TUBE NOTCHER(STEEL)

Model. PNP-3/4-3"

Order Code P092

Edition No : PNP-3/4-3"-1

Date of Issue : 11/2021

www.machineryhouse.com.au

SPECIFICATION

Order Code	P092
MODEL	PNP-3/4-3"
Machine (Type)	Hand Drill Tube Notcher
Notching Cutter (Type)	Hole Saw (Optional)
Tube Capacity (OD) - Mild Steel (mm)	Ø20~ Ø75mm
Angle Adjustment (degree)	0 ~ 50
Minimum Hand Drill Chuck Size (mm)	12mm
Hole Saw Mounting Thread (Inch)	1/2" x 20tpi, 5/8" x 18tpi
Dimensions (L x W x H) (mm)	280 x 180 x 100
Nett Weight (kg)	10

SAVE THIS MANUAL

You will need this manual for the safety warnings and precautions, assembly instructions, operating and maintenance procedures, parts list and diagram. Keep your invoice with this manual. Write the invoice number on the inside of the front cover. Keep the manual and invoice in a safe and dry place for future reference.

IDENTIFICATIONS

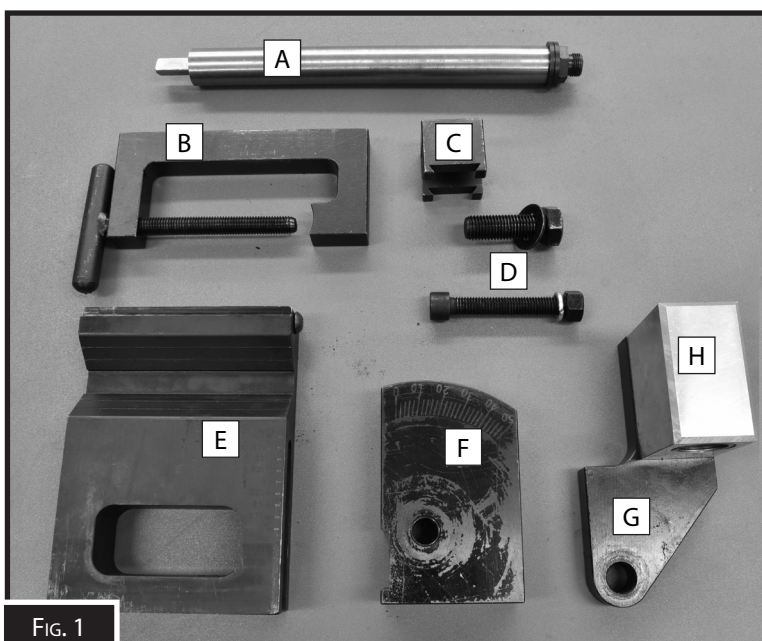

FIG. 1

A	Arbor Shaft
B	Tube Clamp
C	Tube Clamp Slider
D	Bolts
E	Main Frame
F	Base
G	Swivel Plate
H	Bearing Block

SAFETY WARNINGS AND PRECAUTIONS

1. **Keep the work area clean.** Remove any slip or trip items in the work area.
2. **Observe work area conditions.** Do not use machines or power tools in damp or wet locations. Don't expose to rain. Keep work area well lite. Do not use electric powered tools in the presence of flammable gases or liquids.
3. **Keep children away.** Children must never be allowed in the work area. Do not let them handle the machines, tools, or extension cords.
4. **Store idle equipment.** When not in use, tools must be stored in a dry location and coated with light oil to prevent rust. Always lock up tools and keep them out of reach of children.
5. **Do not force the tool.** It will do the job better and more safely at the rate for which it was intended. Do not use inappropriate attachments in an attempt to exceed the tool capacity.
6. **Use the right tool for the job.** Do not attempt to force a small tool or attachment to do the work of a larger industrial tool. Do not modify this tool and do not use this tool for a purpose for which it was not intended.
7. **Dress properly.** Do not wear loose clothing or jewelry as they can be caught in moving parts. Protective, non-conductive clothes and non-skid footwear are recommended when working. Wear restrictive hair covering to contain long hair.
8. **Use eye and ear protection.** Always wear ANSI approved impact safety goggles. Wear a full face shield if you are producing metal filings or wood chips. Wear an ANSI approved dust mask or respirator when working around metal, wood, and chemical dusts and mists.
9. **Do not overreach.** Keep proper footing and balance at all times. Do not reach over or across running machines. Keep hands and fingers clear of moving parts when operating.
10. **Maintain tools with care.** Keep tools sharp and clean for better and safer performance. Follow instructions for lubricating and changing accessories. Inspect tool cords periodically and, if damaged, have them repaired by an authorized technician. Handles must be kept clean, dry, and free from oil and grease at all times.
11. **Remove adjusting keys and wrenches.** Check that keys and adjusting wrenches are removed from the tool or machine work surface before plugging it in.
12. **Stay alert.** Watch what you are doing, use common sense. Do not operate any tool when you are tired.
13. **Check for damaged parts.** Before using any tool, any part that appears damaged should be carefully checked to determine that it will operate properly and perform its intended function. Check for alignment and binding of moving parts; any broken parts or mounting fixtures; and any other condition that may affect proper operation. Any part that is damaged should be properly repaired or replaced by a qualified technician. Do not use the tool if any switch does not turn on and off properly.
14. **Do not operate tool** if under the influence of alcohol or drugs. Read warning labels if taking prescription medicine to determine if your judgment or reflexes are impaired while taking drugs. If there is any doubt, do not operate the tool.
15. **Maintenance.** For your safety, service and maintenance should be performed regularly by a qualified technician.
16. **Workpiece may be sharp.** After bending or cutting workpieces use caution. Be aware of sharp edges or sharp shreds of metal that may be created. Use heavy duty gloves when handling the workpiece.

UNPACKING

This tool was carefully packaged for safe transport. When unpacking, separate all enclosed items from the packaging materials and inspect them for shipping damage. If items are damaged, please contact your distributor.

NOTE: Save all the packaging materials until you are completely satisfied with the machine and have resolved any issues with the distributor, or the shipping agent.

ASSEMBLY

1. Clamp the main frame in a vice to secure it while the notcher is being assembled. (Fig. 2)
2. With the degree scale facing up, attach the base onto the side of the main frame using the M12 x 80 bolt supplied. (Fig. 2)
3. Place the tube clamp slider over the tube clamp and slide this assembly on to the dovetail slide on the main frame from the bearing block end and retain with the button head screw. The T-Handle can be adjusted to clamp the material into the V of the main frame (Fig. 3).
4. Onto the base attach the swivel plate using the M12 x 60 Bolt and Flat washer supplied. (Fig. 4)
5. Smear the roller bearing in the bearing block with a light grease, then place the un-threaded end of the arbor shaft into the bearing block and insure that it moves freely. (Fig. 5)

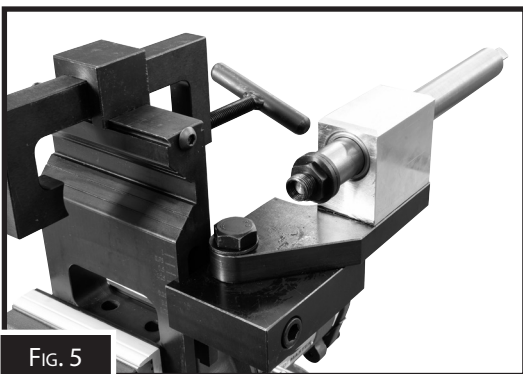
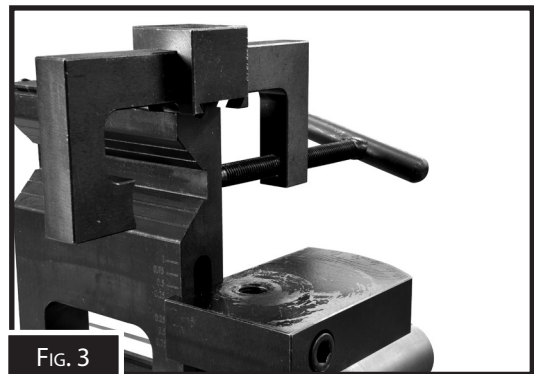
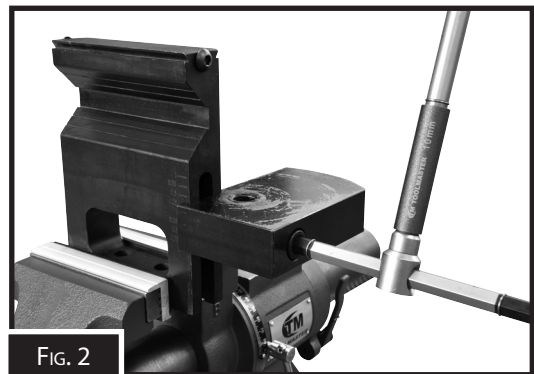

OPERATION

The instructions in this section are written with the understanding that the operator has the knowledge and skills to operate this tool. If you have difficulties performing any operation, stop using the tool and seek advice.

Note: Always ensure that the notcher is securely held in a bench vice or attached to a bench using the bolt holes provided in the base of the main frame.

1. Set the Offset of the cutter to the required position by using the scale on the main frame. (Fig. 6)
2. Set the angle of the notch to be cut in the tubing, by loosening the centre lock bolt slightly and adjust the Arbor Carrier to the desired angle using the gauge, then tighten the lock bolt securely. (Fig. 7)
3. Place the tubing into the "V" notch and secure with the Tubing Clamp.
4. Fit the holesaw to the arbor shaft using the 1/2" threaded mount or the 5/8" adaptor. (Fig. 7)
5. Mount the hand drill to the end of the arbor shaft and set the speed to approximately 500rpm for steel tube. (Fig. 8)

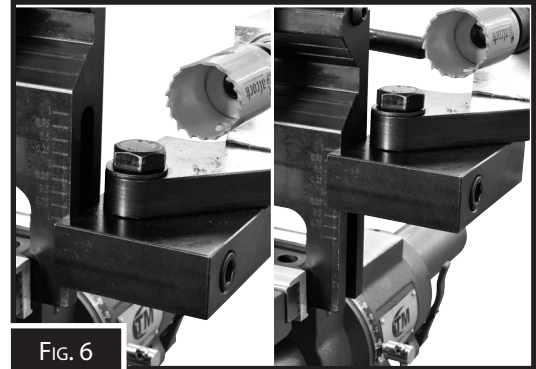

Note The threaded end of the Arbor Shaft has 1/2" thread. This is to accommodate smaller sized hole saws with 1/2" Dia. mount holes. For larger (up to 3") hole saws an adaptor with 5/8" Dia. mounting holes is also supplied. If the 5/8" adapter is to be used, be sure that it is securely tightened.

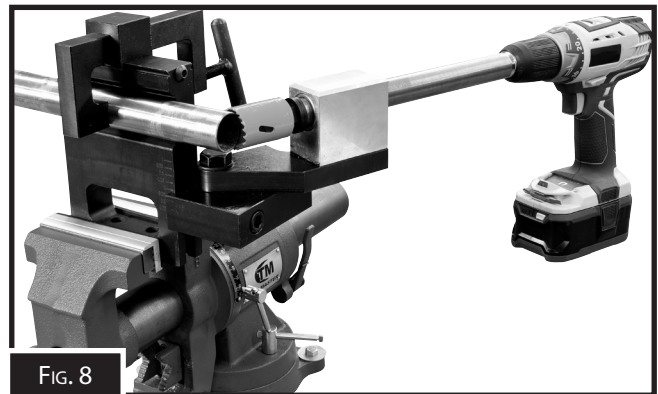

MAINTENANCE

1. Please observe good shop practices for your safety and to extend the work life of your tools.
2. Periodically brush away cuttings and debris from the Tube Notcher, especially the bearing and spindle area to avoid scoring or binding these components.
3. Use a suitable light grease on the bearing to prevent overheating and wear.
4. Be sure to carefully align the drill spindle and the Tube Notcher spindle to prevent binding.
5. After use, clean the Tube Notcher, and apply a light lubrication to all moving parts and unpainted metal to prevent rust.
6. Store the Tube Notcher, well covered and in a dry, dust free place.
7. Help avoid injury by preventing access to this tool by unauthorized persons and children.